

1347

1348

1349



Ecopower+

2500/5000/10000

INSTALLATION AND OPERATING INSTRUCTIONS.
 READ INSTRUCTIONS CAREFULLY BEFORE ATTEMPTING INSTALLATION,
 AND KEEP FOR FUTURE REFERENCE.

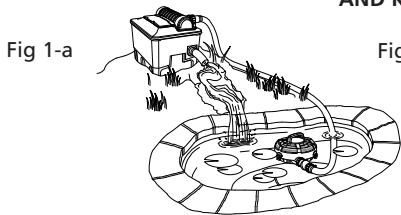

Fig 1-a

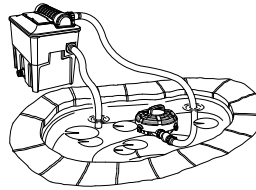

Fig 1-b

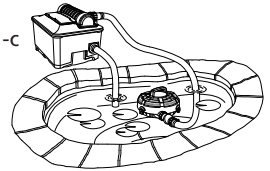

Fig 1-c

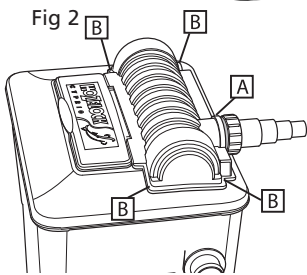

Fig 2

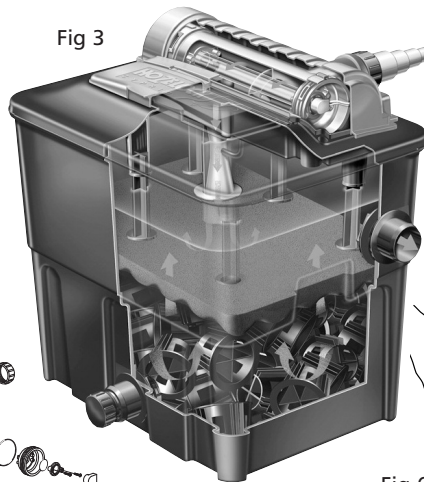

Fig 3

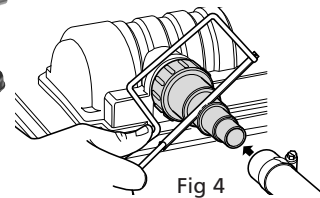

Fig 4

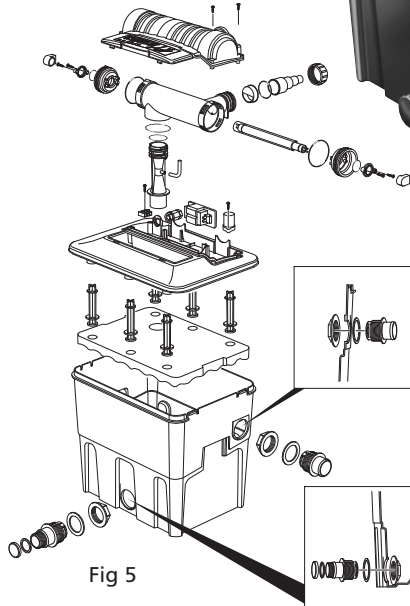

Fig 5

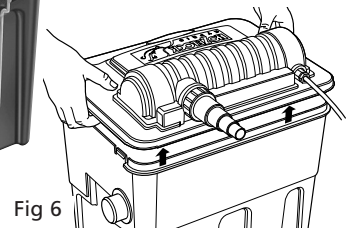

Fig 6

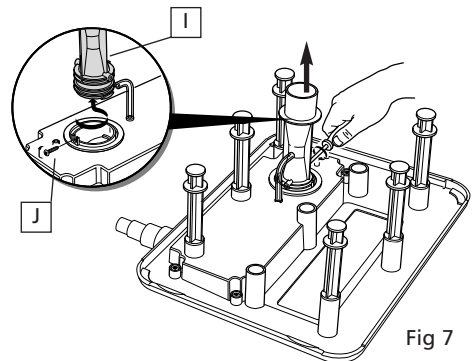

Fig 7

Hozelock Cypro EcoPower+ garden pond filters can be sited almost anywhere. (See a,b,c Fig 1) and teamed with the appropriate pond pump, they will remove unwanted solids from the water and convert dissolved organic and chemical fish waste into harmless compounds. In addition, these combined filter/UVC units will give Guaranteed Clear Water if the advice given in the Hozelock Cypro Filter Equipment Selection Chart and in these instructions is adhered to.

SAFETY AND ELECTRICAL CONNECTIONS

From 1st January 2005 installing this product in the garden is classed as 'notifiable' in the revised Building Regulations for England and Wales. The Regulations now require you to tell your local authority building control department that you intend to install this product before installation. Your local authority will let you know how you can get your installation approved.

Safety Information

The appliance is not intended for use by persons (including children) with reduced physical, sensory or mental capabilities, or lack of experience and knowledge, unless they have been given supervision or instruction concerning use of the appliance by a person responsible for their safety. Children should be supervised to ensure that they do not play with the appliance.

(Australia & NZ only) This appliance is not intended for use by young children or infirm persons unless they have been adequately supervised by a responsible person to ensure that they can use the appliance safely. Young children should be supervised to ensure that they do not play with the appliance.

The appliance is not intended for use by persons (including children) with reduced physical, sensory or mental capabilities, or lack of experience and knowledge, unless they have been given supervision or instruction concerning use of the appliance by a person responsible for their safety. Children should be supervised to ensure that they do not play with the appliance.

! Always disconnect all equipment in the pond before starting to handle, maintain, repair or install any pond equipment.
! This product is **NOT SUBMERSIBLE**, and should be sited where it cannot fall into the water or become waterlogged. However, the design is weatherproof and EcoPower+ filters can be safely installed outdoors.
! Important – This product is not suitable for use in direct sunlight over long periods of time, as this may cause the product to overheat.

! Direct exposure to ultra-violet light can damage eyes and skin. **DO NOT** attempt to view the ultra-violet lamp when lit. To check the lamp look at the opaque inlet Connector (See 'A' Fig 2) which will glow when the lamp is on.
! This product is supplied complete with 3m of 3 core electric cable. For connection to the mains supply, use only three-core cable Ref: H05 RN-F. This has a minimum copper cross-section of 0.75mm² with Polychloroprene Rubber Insulation. The

termination to the mains supply should be permanent, inside a dry weatherproof enclosure, through a double pole switched fused spur with a minimum contact gap of 3mm - (disconnected) to BS 3676 - and fitted with a 3 or 5 amp fuse.

! Exposed cable runs should be sensibly positioned, and protected if necessary by armoured conduit, especially if contact is likely with gardening equipment such as forks and lawn mowers, or children and animals.

! A 10mA or 30mA Residual Current Circuit Breaker (RCD) MUST be fitted to the mains supply.

! Permanent installations to the mains supply (hard wiring) must comply with the regulations of the local electricity authority, which may stipulate the use of plastic or metal conduit to protect the cable.

! If in any doubt about wiring to the mains supply, consult a qualified electrician or your local electricity authority.

! Protect from frost. In cold winter weather (when fish are not active and algae growth ceases), the unit may be switched off. It should then be drained of water, removed (if possible) from its installation and stored in a dry, frost-protected area.

SIZING THE EQUIPMENT

The Filter Equipment Selection Chart overleaf gives general guidelines on the specifications of pump, filter, UV and flexible hose diameter for garden ponds up to 10000 litres (2200 gallons), with stocking options for goldfish or Koi. For best results the following condition factors must also be taken into account.

DEPTH

Hozelock Cypro recommends a minimum depth of 1.2m (4') for Koi ponds. For a pond with an average depth of less than 0.75m (2' 6") the Condition Factor is + 25% (ie add 25% to the pond volume if less than 0.75m deep) Shallow ponds are subject to full penetration of sunlight, and warm up quickly. This encourages the growth of algae.

INSTALLATION

Locate the EcoPower+ on firm, level ground where you can access it conveniently for maintenance.

LOCATION

Pond location determines the daily amount of sunlight or shade a pond receives. Ponds exposed to full sunshine throughout the day have a Condition Factor of +25%.

CLIMATE

Climate affects water temperatures and fish activity rate/feeding requirements. The more active the fish, the greater the demands on the filtration system.

In hot climates (i.e. South Africa), the Condition Factor is +35%
In temperate climates (i.e. Southern Europe), the Condition Factor is +15%
In a Northern European climate (i.e. most areas of Great Britain), the Condition Factor is +0%.

EXAMPLE

You have a 2250 litres (500 gallon) goldfish pond 0.6m (2') deep (Condition Factor +25%). You live in London - a Northern European climate (Condition Factor +0%). The pond is exposed to full sunlight (+25%). The effective volume of your pond is therefore increased by 50% (25% + 25%), and you would need to size your equipment as though your pond held 3375 litres (750 gallons)

1.0 Wiring and Installation

Important:

The pump supplying this unit must not have a maximum head exceeding 6m (3.8 PSI, 0.3

Bar) The table in these instructions will guide you through the best pump to be fitted with your filter. This product is designed to be permanently wired to a mains supply housed in a dry, weatherproof enclosure. Once installed the water will flow through the filter as shown in Fig 3

1.1 EcoPower+ filters are pump-fed, external filters with an integral UVC unit, ideal for being partially buried adjacent to your pond or being positioned above ground if desired. The filter may also be concealed at the top of a waterfall (See a, b, c Fig 1)

If you choose to part-bury your EcoPower+ filter, the excavation should be firmly backfilled with compacted sand or soil to support the unit.

1.2 EcoPower+ filters incorporate inlet hose tails to fit 20 - 40mm (¾" - 1½") hose (refer to Equipment Selection Chart overleaf) and an outlet hose tail to fit 40mm (1½") hose. The pump inlet and filter outlet pipe should be at opposite ends of the pond for optimal water circulation in the pond. Bear this in mind when purchasing, measuring and cutting the hose.

1.3 Cut the inlet hose tail on your EcoPower+ Filter to the size appropriate for the diameter of the hose to be used (see Fig 4). Then connect the hose from your pump to this inlet hose tail and secure with hose clips, available separately, to ensure there are no leaks. Do not overtighten.

1.4 The filter outlet connector and overflow moulding (x2 on EcoPower+ 9000) should be secured to the side of the vessel (See Fig 5). The outlet hose (if fitted) should be secured in the same way as the inlet hose. Avoid kinks and bends, and keep hose runs as short as possible (preferably less than 1m) to minimise flow restrictions.

1.5 The supply cable cannot be replaced. If the cable is damaged, the unit should be discarded.

! WARNING:

This appliance **MUST** be earthed, and it is essential that the connections be made using the following code:

- The **BROWN** lead should be connected to the **LIVE** terminal marked 'L'.
- The **BLUE** lead should be connected to the **NEUTRAL** terminal marked 'N'.
- The **GREEN/YELLOW** lead should be connected to the **EARTH** terminal marked '⏏'.

1.6 Wet Test: It is essential that the unit is wet tested before connecting to the mains electricity. With the electrical cover / viewing hatch removed, connect the hoses to the inlet and outlet as described in 1.4 above. Switch on the **PUMP ONLY** and run for an hour. Inspect the top of the unit and inside the quartz glass tube for leaks (see Figs 8, 9 & 10). If any leaks are detected return the filter to the retailer. This test should be repeated when the quartz glass tube is changed.

2.0 UVC LAMP REPLACEMENT

EcoPower+ is supplied with a UVC lamp fitted.

! The effective life of a double-ended UV lamp is 12 months in continuous use, after which time the lamp should be replaced. Even though it may still glow the light emitted is not powerful enough to treat the water

2.1 Switch off and isolate (by removing the fuse) the pump supplying water to the filter and the power supply to the EcoPower+ unit. Remove the electrical cover / viewing hatch (see Fig 8).

2.2 Pull off the lamp terminals (see 'G' Fig 10) from both ends, and slide the 'old'

lamp out of the quartz tube (see 'H' Fig 11). Slide the 'new' lamp into the quartz tube and push the lamp terminals onto both ends of the UVC lamp.

- 2.3 Replace the electrical cover / viewing hatch and tighten the four fixing screws. Switch on the power supply to the Ecopower+ and check via the indicator (see 'A' Fig 2) which will glow when the lamp is on.

3.0 FLOW RATE

3.1 The pond volume should pass through the Ecopower+ every 1½ - 2 hours, the fastest flow rate being recommended for Koi ponds. Do not exceed the maximum, as stated in the Equipment Selection Chart overleaf. Correct flow rate is essential if you are to obtain clear water. If your installation does not suffer from high losses of flow (i.e. long hose runs) it may be necessary to adjust the flow down to achieve the 1½ - 2 hour turnover rate using a Hozelock Cyprio Flow Control Hose Tap.

3.2 Small diameter hose, unnecessarily long hose runs and a high pumping lift ('head') can all considerably reduce water flow from the pump to the filter. We recommend choosing a pump that will deliver the required flow for the filter against full static lift (= vertical distance between pond surface and filter inlet), plus 0.6m (2ft) to allow for friction losses in hoses.

3.3 The object of filtration is to transfer waste material from the pond into the filter, and therefore any pump used as part of the package should be capable of handling solids. We recommend the Hozelock Cyprio Titan filter pump, specifically designed for ponds in the size range covered by Ecopower+. The pump should be positioned on the bottom in the deepest part of the pond, as this is where solids accumulate.

3.4 How to check your flow rate:

Take a container of a known volume and time how long it takes to fill (in seconds). Then divide 3600 by the number of seconds it takes to fill the container, and multiply by the volume (litres or gallons) of the container. The result will be the flow rate in gallons or litres per hour ie Flow Rate Litres per hour LPH = (container volume m³ x 1000) / (3600/time 's' to fill container). To get gallons per hour GPH divide answer by 4.5

4.0 PERIODS OF OPERATION

Maintain filtration 24 hours a day throughout the fish-feeding season (until water temperature falls below 10°C), but preferably all year round. In the winter, operating the pump and filter will maintain a background level of friendly bacteria in the Ecopower+, and will help prevent the pond icing over in all but the severest weather conditions. If the pump is switched off for winter, the filter media

(foam and/or plastic biomed) must be thoroughly washed before resuming filtration in the spring, and your Ecopower+ will need to be re-matured from scratch (see 'Maturation' 6.0). Never feed your fish when the filter is not in use.

5.0 FISH STOCKING DENSITY

Under normal conditions and feeding, the Ecopower+ range will support up to 50cm of fish (2 fish 25cm long or 5 fish 10cm long) per 1000 litres (10" of fish per 100 gallons) of pond capacity. Introduce fish slowly over the first few weeks, up to 20% of maximum recommended level, increasing this if you wish to 50% after six months. The balance will allow for fish growth.

6.0 MATURATION

6.1 Biological maturation means that the filter has built up sufficient nitrifying bacteria to convert harmful fish and other organic waste (i.e. Ammonia, Nitrite) into harmless Nitrate. The process normally takes 6 - 8 weeks, but is dependent upon many factors such as water temperature, feeding rate and stocking density. It is recommended that you do not switch your UVC on during this period. We strongly recommend the use of Hozelock Cyprio test kits at all times to check water quality, but especially during this critical period. The kits contain full instructions and invaluable pond management advice.

7.0 CLEANING YOUR Ecopower+

7.1 Ecopower+ filters deliver maximum performance with minimum maintenance. However, as the foam blocks up less water can flow through the foam and cleaning becomes necessary. If the pond is very dirty, the filter may need cleaning every few days at first, as it takes up waste matter very quickly. Once the pond becomes clearer, there will be less waste to remove and the filter will need cleaning less often.

! WARNING:

Prolonged running of the filter when it needs cleaning will result in difficulty in cleaning and may reduce the life of the foam.

7.2 Switch off and isolate (by removing the fuse) the pump supplying water to the filter when it needs cleaning and the power supply to the Ecopower+ unit. Gently remove the lid from the vessel.

7.3 The foam is secured onto the ends of the spacers and the venturi tube. Remove the foam (Fig 12) and rinse it in the water left in the vessel. Do not over clean. Drain the vessel of all the waste and water.

7.4 The venturi outlet (see 'I' Fig 7) from the UVC chamber can be removed for cleaning if required. To remove, unscrew the venturi locking screw (see 'J' Fig 7) Twist and unlock the bayonet and lift the venturi away. To replace, repeat the

above in reverse

7.5 Reposition the clean foam sheet onto the ends of the foam spacer ensure that the foam is positioned with the venturi passing through it and with the dimples in the foam facing upwards.

7.6 Gently locate the lid onto the vessel and snap down around the rim. Looking through the viewing hatch, ensure that the foam sheet is positioned below the outlet.

7.7 Restart the pump, checking for leaks, which if left undetected could result in the pond being drained of water. Switch the supply to the Ecopower+ on and check via the indicator, (see 'A' Fig 2) that the UVC lamp is working.

8.0 CARE OF THE UV QUARTZ TUBE

8.1 Especially in hard water areas the quartz sleeve sheathing the UVC lamp may become covered in lime scale. This will reduce the efficiency of the unit if it is allowed to build up. To clean, switch off and isolate (by removing the fuse) the pump and the power supply to the Ecopower+. Unscrew the four screws (see 'B' Fig 2) and remove the electrical cover / viewing hatch as shown in Fig 8.

8.2 Remove the UV lamp as described in 2.2. Slacken the two quartz clamp screws (see 'K' Fig 9) at both ends to release the quartz tube. Slide the quartz tube out of the UVC unit (See Fig 10). Wipe quartz tube with a soft cloth moistened with a gentle cleaning agent (e.g. vinegar)

8.3 Slide the quartz tube back into the UVC unit, ensuring equal lengths protrude from both ends of the UVC unit. Tighten the two quartz clamp screws at both ends to hold the quartz tube firmly in position.

8.4 Before switching the UV lamp on restart the pump checking for leaks. Replace the electrical cover / viewing hatch and tighten the four fixing screws (see 'B' Fig 2). Providing there are no leaks, switch on the power supply to the Ecopower+.

9.0 WINTER STORAGE

Important:

When not in use, the unit should be removed, thoroughly washed and cleaned, dried and stored in a dry frost protected area. Always store the unit with the lid off to ensure adequate ventilation and drying.

10.0 PERFORMANCE GUARANTEE WE GUARANTEE YOU CLEARWATER OR YOUR MONEY BACK.

This guarantee runs for 12 months after purchase, provided that:

- You have followed the installation and operating instructions;
- You are using equipment of the correct size, according to the pond sizing chart below
- You consult our Helpline (0121 313 1122) early enough for any problems to be put right

Filter Equipment Selection Chart

Chart for guidance only. Based upon 4m length Cypriflex pond hose, 1 metre static lift from pond water level.

Model		Max Pond Size Litres (Gallons)	Max Flow rate Litres/Hour	Recommended Pumps	UVC Supplied Watts	Recommended Hose Internal Diameter	
						Inlet	Outlet
2500	No Fish	5000 (1100)	1250 (275)	Titan 2000	6	20-40mm	40mm
	Fish	2500 (550)	1250 (275)				
5000	No Fish	10000 (2200)	2250 (500)	Titan 3000	8	20-40mm	40mm
	Fish	5000 (1100)	2250 (500)				
10000	No Fish	20000 (4400)	4500 (1000)	Titan 5500	16	20-40mm	40mm
	Fish	10000 (2200)	4500 (1000)				

- The product has been returned undamaged
- A refund can only be authorised by Hozelock Cyprio and is made at the place of purchase.

SPARE PARTS

Spares	Ecopower+		
	2500	5000	10000
Foams	1364	1364	1364
Lamps – Double Ended	Z11106	Z11108	Z11116
Quartz Tube	Z11216	Z11226	Z11226
O'Ring Kit	Z11660	Z11660	Z11660

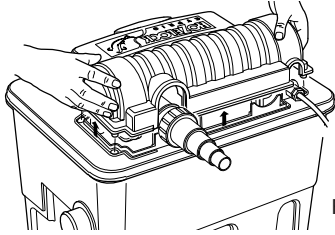

Fig 8

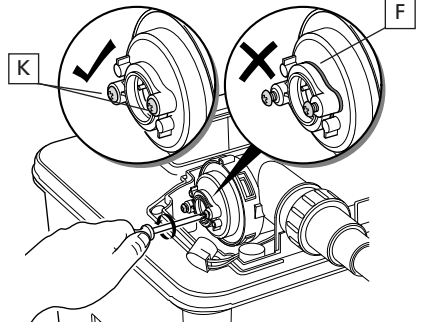

Fig 9

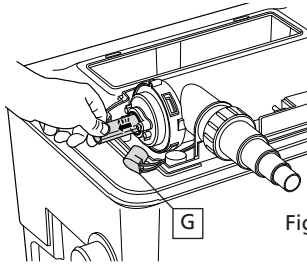

Fig 10

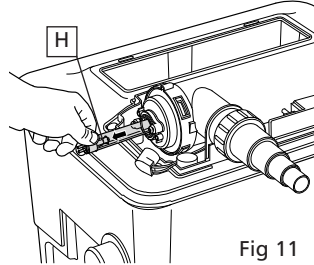

Fig 11

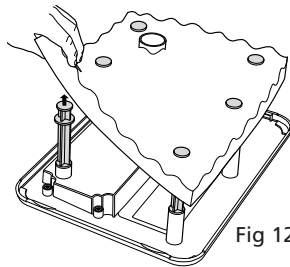

Fig 12



Hozelock Cyprio
 Midpoint Park, Birmingham B76 1AB
 Tel: +44 (0)121 313 1122

www.hozelock.com

The Aquatics Division of Hozelock Group

33857-003

